

SECTION A-A

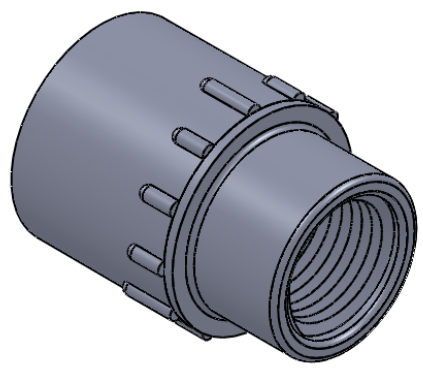

DURA DURA PLASTICS PRODUCTS
 533E Third Street Beaumont CA 92223
 Phone:(951)845-3161 Fax:(951)845-7644

File Name :435-101		NAME	DATE
PROPRIETARY AND CONFIDENTIAL THE INFORMATION CONTAINED IN THIS DRAWING IS THE SOLE PROPERTY OF DURA PLASTIC PRODUCTS . ANY REPRODUCTION IN PART OR AS A WHOLE WITHOUT THE WRITTEN PERMISSION OF DURA PLASTIC PRODUCTS IS PROHIBITED.	UNLESS OTHERWISE SPECIFIED: DIMENSIONS ARE IN INCHES TOLERANCES: FRACTIONAL: ±1/32 ANGULAR: ± 1/2° TWO PLACE DECIMAL ±.010 THREE PLACE DECIMAL ±.005	DRAWN	PDOAN 11-29-10
		CHECKED	
		ENG APPR.	
		MFG APPR.	

SIZE	Description:
A	(435-101) 3/4" SLIP x 1/2" FIPT
SCALE: 1:1	REV : .01
	SHEET 1 OF 1